



BOSCH

Invented for life

Akustica, Inc.

BMU537R

Differential Analog MEMS Microphone

General Description

BMU537R is an HD Voice quality, bottom-port, **differential** analog output MEMS semiconductor microphone. It is a microphone consisting of a MEMS acoustic sensor and an integrated circuit (IC) with a pre-amplifier, charge pump, and supporting circuitry in an industry standard package footprint of 3.35mm x 2.50mm x 0.98mm.

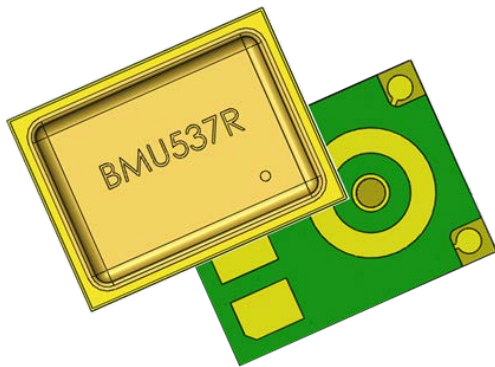

Product features

Designed specifically to provide ultra-high acoustic performance in a small footprint package, the BMU537R is ideal for use in mobile handsets, set-top-boxes, TV remote controls, and other applications requiring excellent acoustic performance for speech recognition and far-field applications. The BMU537R offers 66dB signal-to-noise ratio (SNR), and uniform sensitivity matching of just +/-1dB between microphones. It also provides a flat wideband frequency response delivering uniform audio capture across a broad audio spectrum.

The BMU537R gold-plated metal lid package is immune to RF and Electromagnetic (EM) interferences, allowing for easy integration into wireless devices.

TECHNICAL DATA	BMU537R
Package Dimension (mm ³)	3.35 x 2.50 x 0.98
Temperature Range	-40°C to +100°C
Supply voltage (VDD)	1.62V ... 3.6V
Directivity	Omni-directional
Signal-to-noise Ratio (SNR)	66dB
Frequency Response	80Hz to 12.5kHz
Sensitivity	-38dB ± 1dB
Acoustic Overload Point (AOP)	130 dB SPL
Power Supply Rejection (PSR)	-90dBV(A)
Current Consumption	245µA
Output impedance	400Ω
Part-to-part Phase Matching	±4°

BMU537R target applications

- ▶ Smartphones and mobile phones which require high quality acoustic performance
- ▶ Voice-activated entertainment systems, set-top-boxes-remote controls
- ▶ Wearable accessories, IoT
- ▶ Gaming consoles and controllers
- ▶ Microphone arrays – multi-mic applications

Functional block diagram

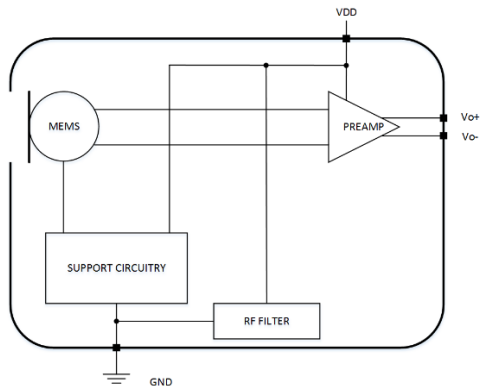

System compatibility

The BMU537R can be easily designed into mobile phones, wearable, and other applications requiring excellent voice capture capability. BMU537R is housed in a gold-plated, metal-lid industry-standard footprint package that is mechanically and electrically robust. The metal-lid package which, in combination with the MEMS sensor design, enable the BMU537R to withstand the many mechanical stresses, from handling or dropping that occur during manufacturing and end-use.

The Faraday cage package construction with enhanced filtering provides of additional radiated RF rejection e.g. in GSM bands. This added RF immunity reduces the burden of external filtering components and decreases the number of necessary board redesign and testing re-certifications, thereby shortening time-to-market and reducing development as well as overall system costs. The microphones can also withstand more than twice the state-of-the art level of ESD air discharge, improving both manufacturing and end-user reliability.

The BMU537R deliver superior electro-acoustic performance, featuring a high signal-to-noise ratio (SNR) of 66dB providing at the same time a uniform sensitivity

(+/- 1dB) and a flat frequency response. Combined with a low-total-harmonic distortion (THD), the BMU563R can noticeably improve call quality and speech recognition accuracy, especially in far-field and array applications.

Additionally, the BMU537R draws only 245µA in full performance mode, making it an attractive solution also for wearable and other application requiring high performance, and low power in a compact form factor.

Total harmonic distortion (THD)

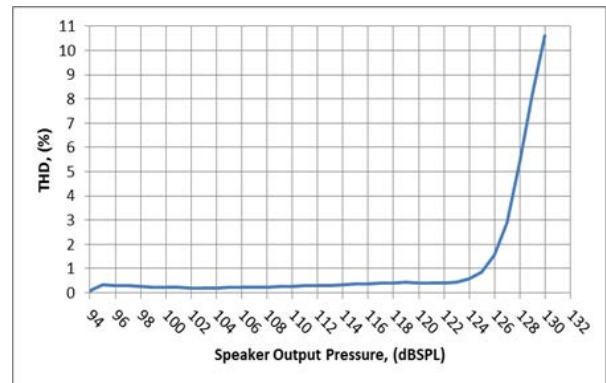

The performance of modern microphone systems are heavily dependent on the overall platform design, including software algorithms, mechanical layout and hardware implementation. As an innovator in the field of MEMS microphones and leveraging significant Consumer Electronics application experience, as part of the Bosch Group, Akustica has a deep understanding of acoustic design requirements and proper analysis methods. To ensure our customers a seamless integration experience and support constrained design cycles, we offer acoustic design and modeling services prior to assembly, and also provide production test services, training, and test equipment to help ensure the quality of both incoming and final assembled products.

**Headquarters
Akustica Inc.**

2555 Smallman Street, Suite 200
Pittsburgh, PA/USA 15222
(412) 390-1730
sales@akustica.com

www.akustica.com